



**Motic®**

MORE THAN MICROSCOPY

# VIS100/VIS200

Video Inspection Scope ●●●●●

# VIS100/VIS200

Video Inspection Scope 

The all new VIS100/VIS200 series, a product by Motic for the industrial field, performs an online or offline probe application, visualization, inspection, observation, measurement, and documentation via monitor or LCD display. Available in manual and semi-automation operation, the VIS100/VIS200 series is compact in size, easy to install and has long working distance.

## APPLICATION EXAMPLES

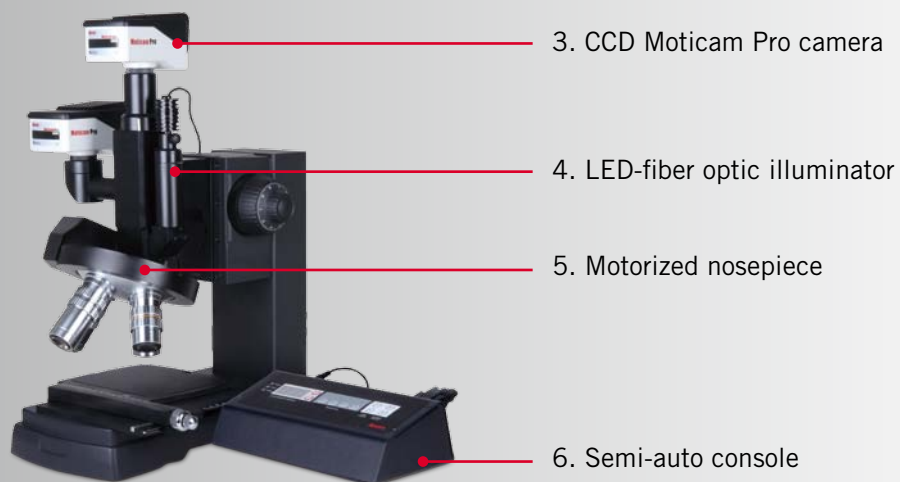
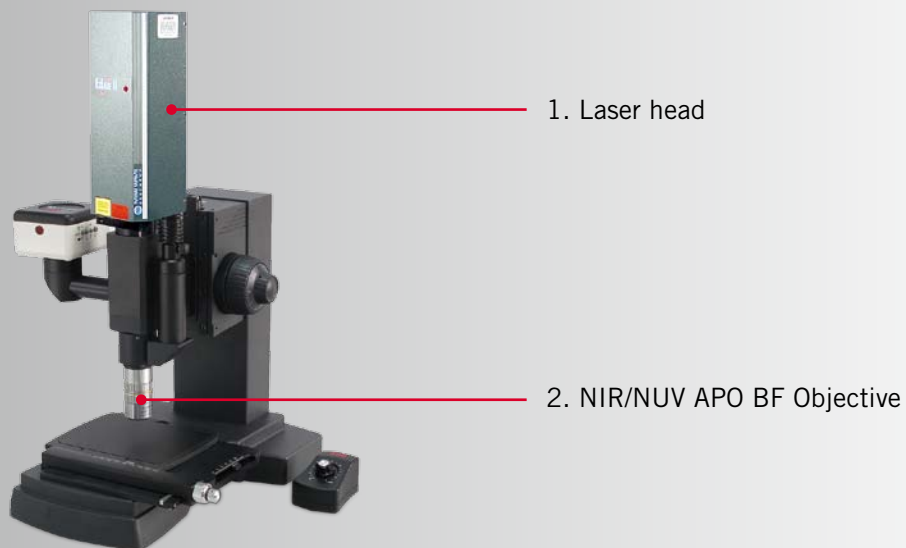

Note: Please be aware the accessories are presented in above photos or following application example or recommendation, such as: Objectives, CCD Moticams, laser head etc., just for demonstration purpose of applications, please contact your local vendor or seller for more details.

The upgradable compact sized VIS100/VIS200 series can be embedded into a probe station and customer integrated system with simple installation. For example:

Max transmission distance is 25ft, VIS100/VIS200 in Customer Inspection System of Flat Panel Display via RS232 serial port connection.

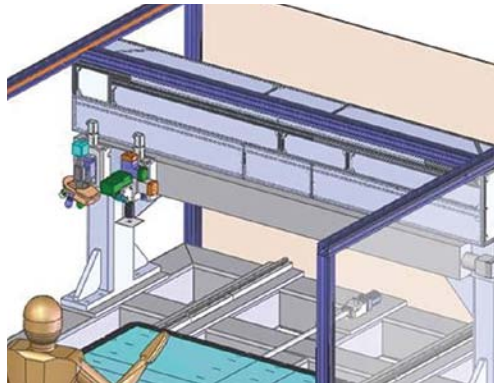

Working distance of 5x APO objective is 34mm, Wafer inspection and fine-film laser-cutting in Probe station.

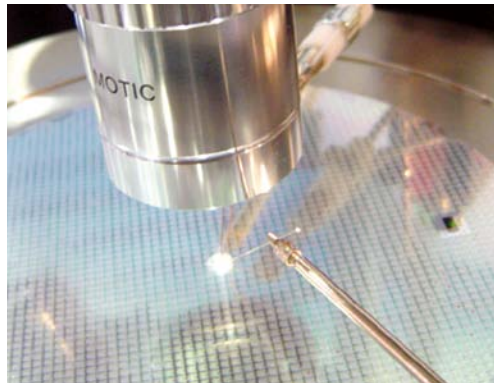

Dimension measurement, contour inspection, positioning as demands etc..



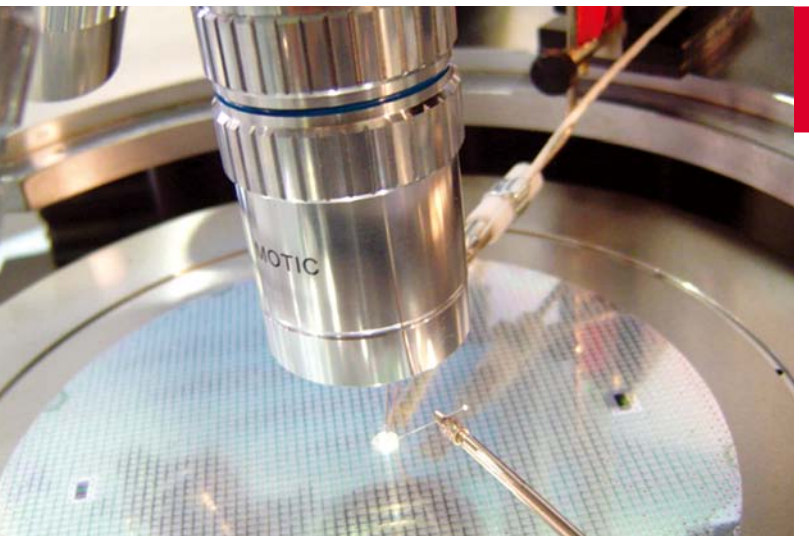

## Laser rework

In order to meet the diversified probe application under video condition, the infinity optical system of VIS100/VIS200 series adopts the “All-in-one” specialized lense design that supports the full popular spectrum wavelength of Probe application: 355nm (NUV), 532nm (Green), 1064nm (NIR). It can also perform laser rework under live video condition via both monitor and display simultaneously.



## Caution!

However, Motic assumes no responsibility for the performance and safety of the laser system used with Motic microscopes. The laser emission may cause unknown harm to health, and therefore, a serious of examination and safety instructions pertaining to the laser usage legislation is strongly recommended while selecting a laser emission unit.



The video observation or probe inspection covers the economic metallurgic application, material research under stereoscopic, high-resolving power and extra/ultra-long working distance. The new VIS100/VIS200 series adopt.

## APO objective

The extra/ultra-long work distance plan APO objectives and the plan NIR objective are both suitable for high tech or precise probe observation, inspection and/or laser rework, such as: micron circuit failure analysis, and sub-micron viewing and quality control of PCBA, Wafer, LCD, LED etc..



Type	Magnification	N.A.	W.D. (mm)	Resolution (μm)	Purchasing part Code
ELWD	2x	0.055	34.0	5.0	1101001700052
	5x	0.140	34.0	2.0	1101001700072
	10x	0.280	33.5	1.0	1101001700032
	20x	0.420	20.0	0.7	1101001700042
	50x	0.550	13.0	0.5	1101001700062
	100x	0.800	3.0	0.34	1101001700021
ELWD PA	2x	0.055	34.0	5.0	1101001700141
	5x	0.140	34.0	2.0	1101001700181
	10x	0.280	33.5	1.0	1101001700112
	20x	0.420	20.0	0.7	1101001700122
ULWD	50x	0.420	20.5	0.7	1101001700092
	100x	0.550	13	0.5	1101001700082
NIR	20x	0.400	20.5	0.7	1101001703531
	50x	0.420	19	0.7	1101001703541

## Infinity corrected plan objective

Infinity corrected plan objective -suitable for economic metallurgic observation or inspection. It can be applied on quality control, engineering analysis etc..



Type	Magnification	N.A.	W.D. (mm)	Purchasing part Code
Infinity corrected objectives	5x	0.13	11.5	1101001401681
	10x	0.30	6.8	1101001401691
	20x	0.40	11.1	1101001401701
	50x	0.55	8.2	1101001401711
	100x	0.80	2	1101001702781



**In case of emergency, the wide field eyepiece and monocular head can switch the VIS series back to eye observation from the monitor or LCD display.**

Type	Magnification	F.N.	Purchasing part Code
Monocular head	-	-	1101006000731
Eyepiece	10x	20	1101001402351
	12.5x	18	1101001402051
	15x	16	1101001402061

**Variety of accessories with combinations of multipurpose nosepiece, illuminator, video C-mount. VIS series can be built on a budget to suit your needs.**

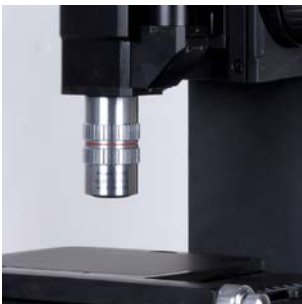

Single nosepiece



Linear nosepiece



Manual nosepiece



Motorized nosepiece

## Excellent LED-fiber optic illuminator with adjustable Aperture Diaphragm

Coaxial LED illuminator for VIS100, VIS200 series is a green, compact and ideal lighting solution for diversified observation.



The 3W LED fiber-optic coaxial illumination with Aperture Diaphragm can achieve an adjustable concentrated light as needed



Low power consumption keeps the work-piece and workshop free from thermal and heat influence.





## VIS100

Only 1 Objective and  
1 CCD Moticam Camera



The convenience to realize online/offline single magnification and rapid inspection through monitor or display in high volume production environment can be achieved.

## VIS200

Application recommendation 1:



To realize online or offline laser reworking, observation judgment simultaneously via beam split lens, like: probe application on Wafer, FPD and laser reworking simultaneously for superb high efficiency.

Application recommendation 2:



To realize online or offline rapid 2 items observation or inspection through monitor or display at same time via Beam split lens, such as : online or offline sort failure, outline contour and feature at same time.

Mode No.	Beam Split		Purchasing part Code
	CCD	Laser Port	
VIS200	20, 50	80, 50	1100101700122
VIS200-M	20, 50	80, 50	1100101700171





### VIS100-S

Linear sliding nosepiece, only carry 2 objectives



To realize only 2 selected magnification objectives or 2 different type objective need for online or offline variety engineering analysis, quality control, failure analysis via monitor or display, or weigh-less or cost efficiency as needs.

### VIS100-M / VIS200-M

Nosepiece location is precisely positioned (8 $\mu$ m) by built-in infrared photoelectric sensor

RS232 serial port(max transmission distance 25 ft) for semi-auto control and be integrated into Customer system



VIS100-M, VIS200-M with motorized nosepiece, is designed to improve the efficiency of high precise repeatable positioned (8 $\mu$ m) observation/inspection requirement in fast speed production for online or offline inspection, laser rework, capturing failure and engineering analysis via monitor or display for complex and multiple task demands at same time, or can be embedded into customized automation system for complex and diversified tasks etc..

### VIS100-E

A small-size, low-price metallurgical microscope combined with high-resolving power metallurgical objectives, stand, X-Y stage, etc.



To meet online or offline observation or inspection, variety quality control and engineering analysis, failure analysis etc..

## SPECIFICATIONS

VIS100 Series						VIS200 Series			
	VIS100	VIS100-S	VIS100-A	VIS100-M	VIS100-E	VIS200	VIS200-S	VIS200-A	VIS200-M
Description	With single objective	With sliding nosepiece	With nosepiece (centering adjustable)	With motorized nosepiece	economical use, Nosepiece with RMS mounting	With single objective	With sliding nosepiece	With nosepiece (centering adjustable)	With motorized nosepiece
Maginification of tube	1X								
Camera mount	Vertical								
Observation image	BF/erect image								
Light distribution	/					20:80 (C-mount: laser mount)			
Tube lens (correction)	1X Applicable wavelength (near-infrared - visible- near-ultraviolet radiation)				1X	1X Applicable wavelength (near-infrared - visible- near-ultraviolet radiation) *mounted on the upright port			
Applicable laser	1064 / 532 / 355mm laser				/	1064 / 532 / 355mm laser			
C-mount adapter	0.5X optional / 1X included					0.5X optional /1X (Adjustable Parfocality) included *mounted on the side port of the body			
Objectives (optional)	For observation	Plan APO ELWD PA 2X / 5X / 10X / 20X, Plan APO ELWD 2X/ 5X/ 10X/ 20X/ 50X/ 100 HNA, Plan APO ULWD 50X/100X			/	Plan APO ELWD PA 2X / 5X / 10X / 20X, Plan APO ELWD 2X/ 5X/ 10X/ 20X/ 50X/ 100 HNA, Plan APO ULWD 50X/100X			
	For laser-cutting	NIR 20X, 50X			/	NIR 20X, 50X			
	For metallurgical application				Plan 5X/ 10X/ 20X/ 50X/ 100X	/			
Applicable camera	1/2 inch or 2/3 CCD camera (C-mount type)								
Illumination system	The 3W LED fiber-optic coaxial illumination with aperture diaphragm								
Light source	Halogen bulb (21V, 150W) (optional)								



# VIS100 Dimensions

VIS100:

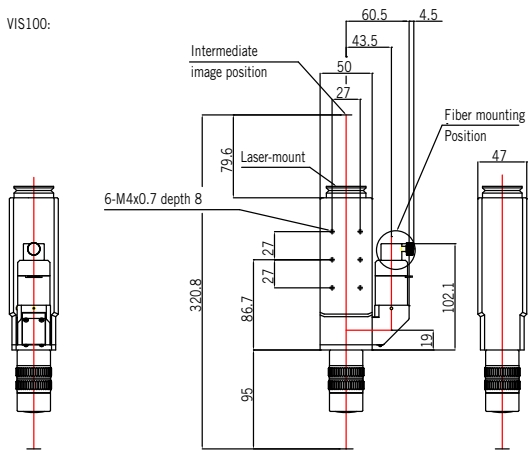

VIS100-S:

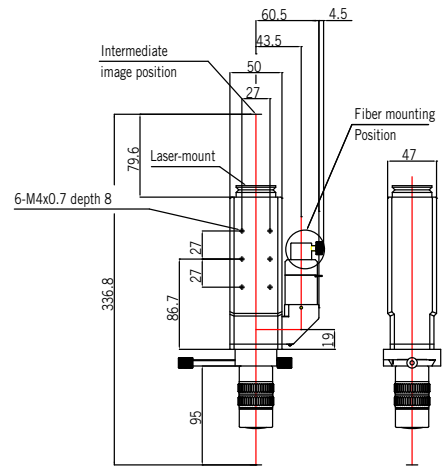

VIS100-A:

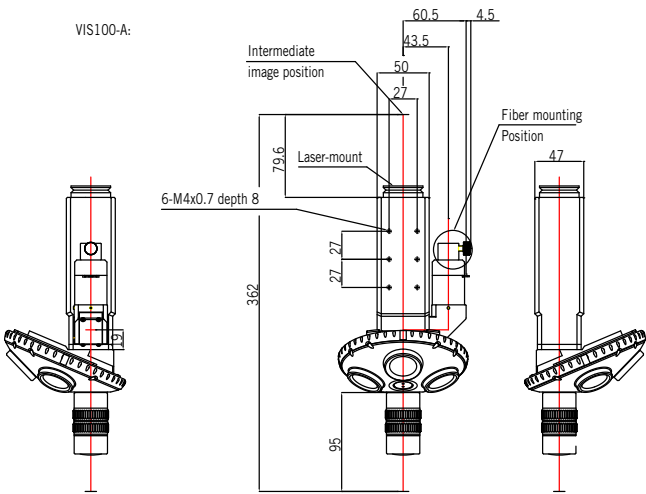

VIS100-M:

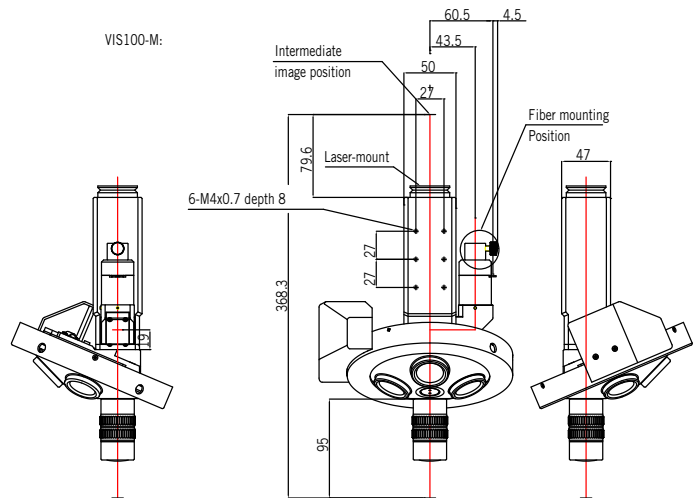

Detail of fiber mounting unit

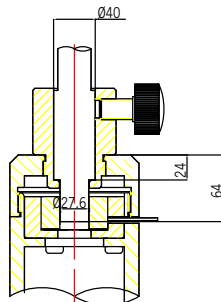

Detail of LED mounting unit

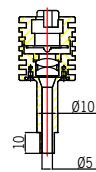

# VIS200 Dimensions

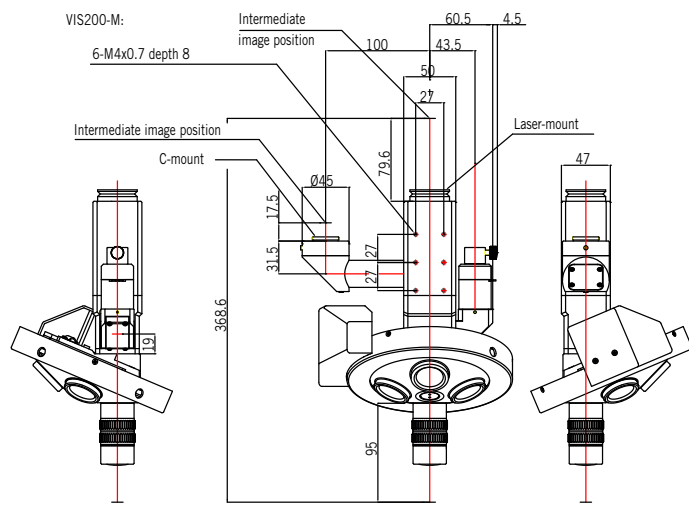
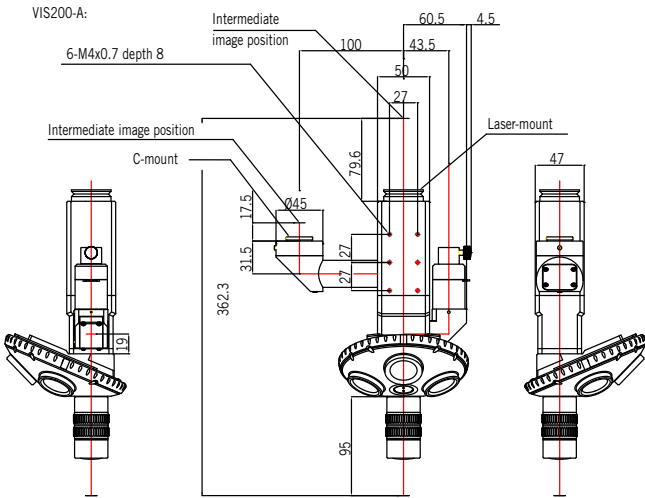
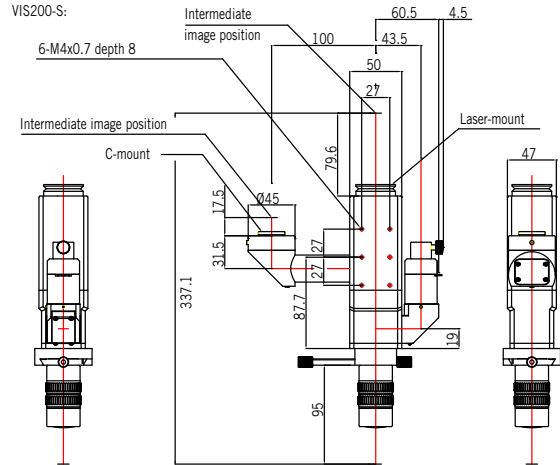
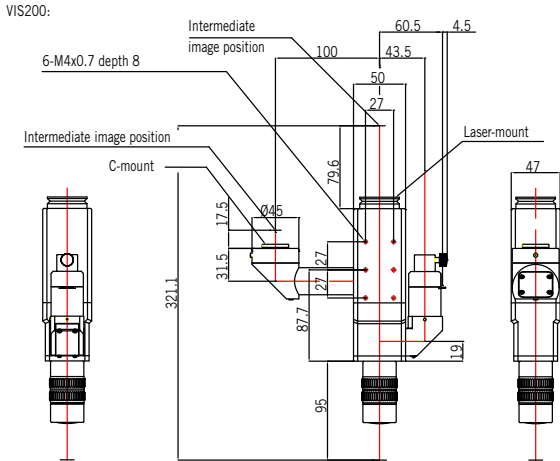

Detail of 1X C-mount adapter

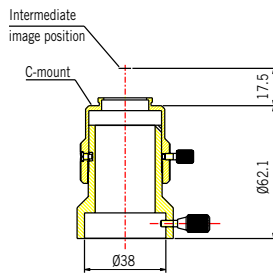

Detail of 0.5X C-mount adapter

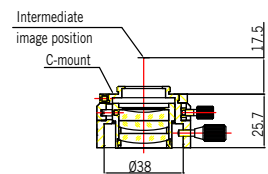

# Accessories Dimension

## Connecting mounter:

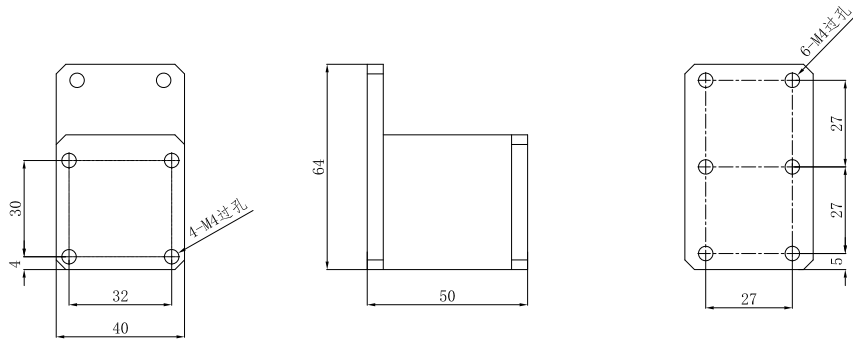
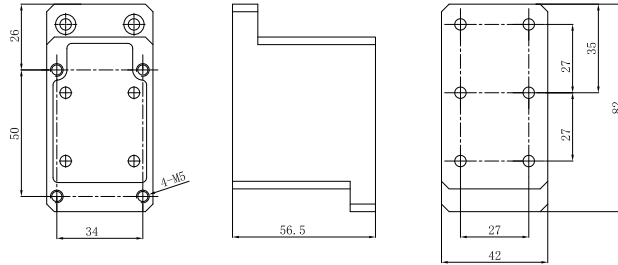

## Focusing block:

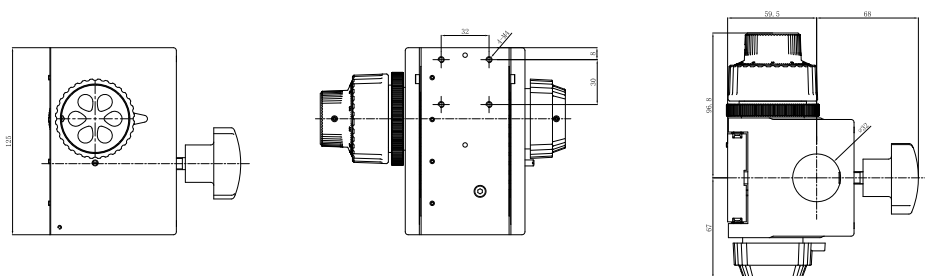
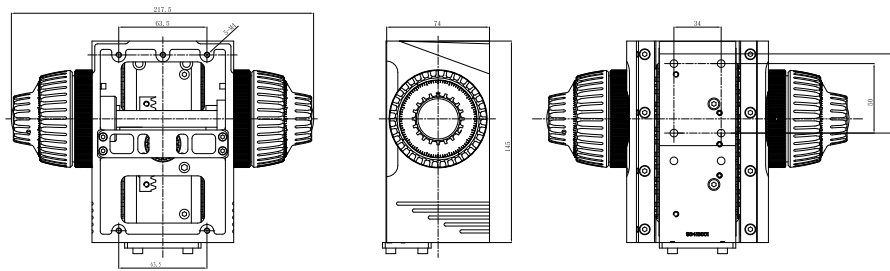

## Mechanical Stage

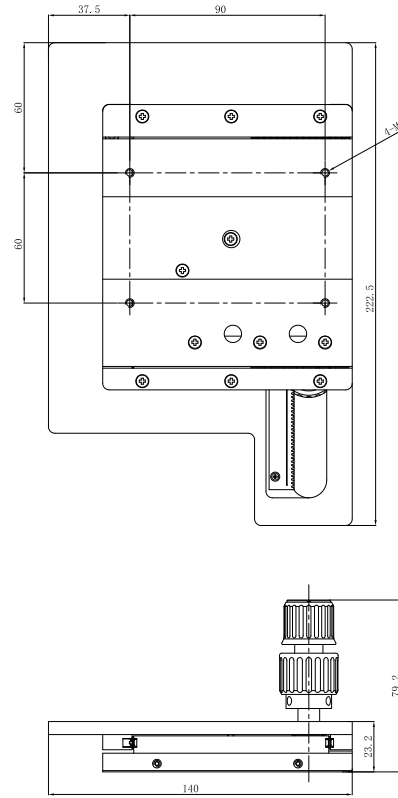
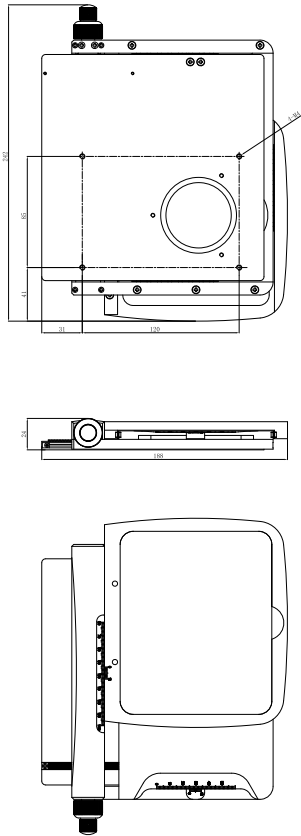

## Fixed arm stand

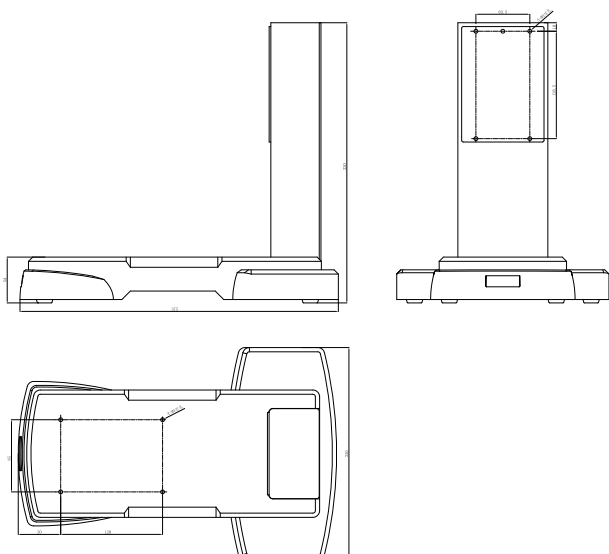

## Pole stand

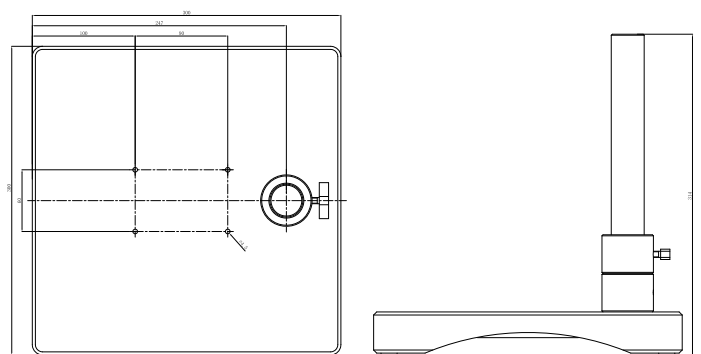

## SYSTEM CONFIGURATION

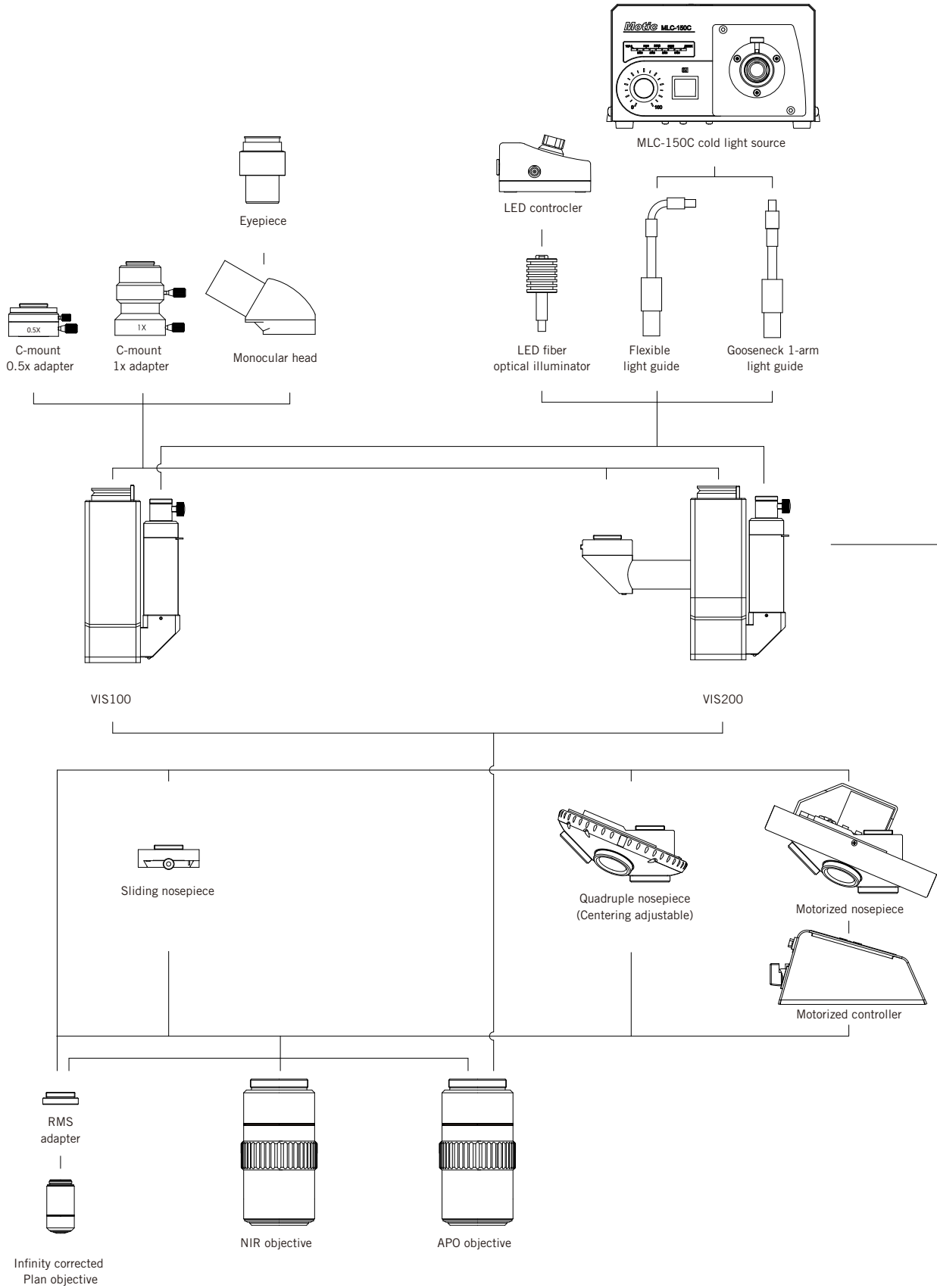



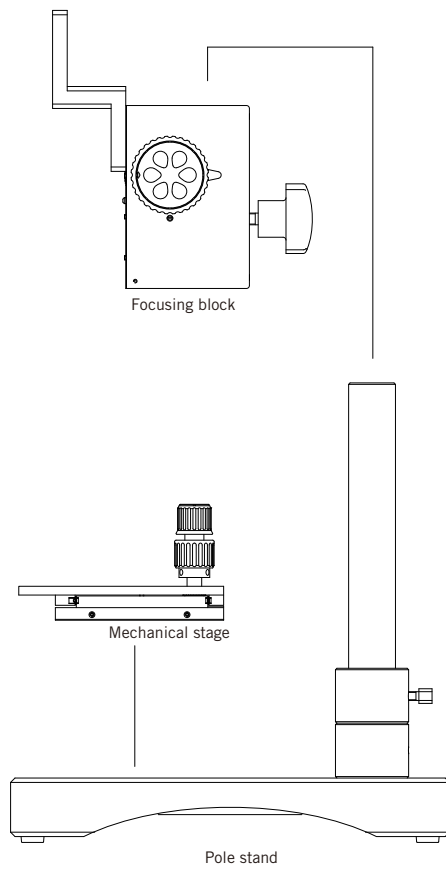
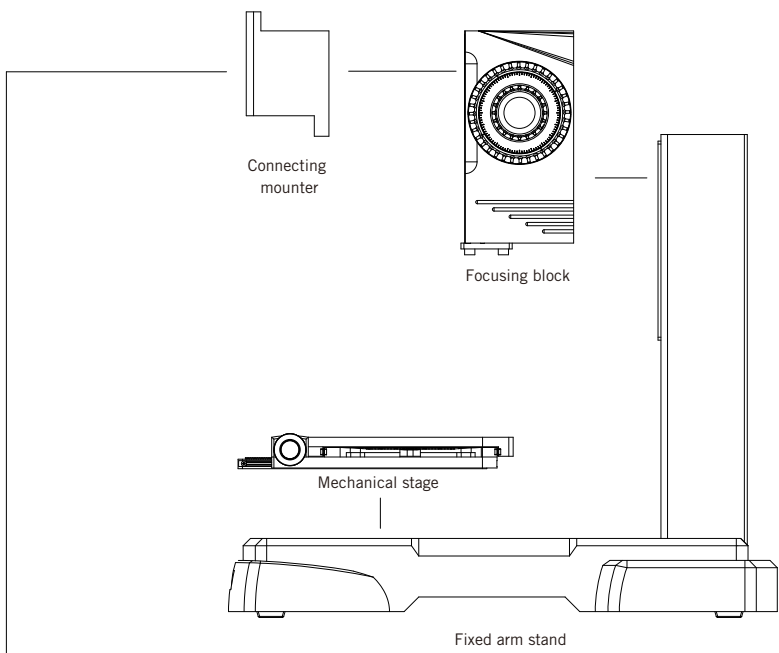



## PRECAUTIONS FOR USE OF THE LASER

### 1. Difference in beam system:

The laser increases its energy density as the laser beam converges. The energy density increases approximately proportionally to the area ratio of a beam system. While configuring an optical system please do exercise seriously to avoid converging the laser inside the optical system.

### 2. Difference in wavelength:

The upper limit value of the input laser in the optical system differs depending on the laser wavelength. The laser photon energy increases as the wavelength shortens. Note that the laser photon energy is reversible proportional to the wavelength.

For example: refer to the case, such as the laser is entered into the objective directly. If the wavelength decreases to  $1/2$ , the photon energy increases by 2 times. Therefore, the upper limit value of the energy density of the laser to be entered in the optical system must be reduced to  $1/2$ .

### 3. Difference in pulse width:

If the pulse width is narrowed, the electric field increases by the square root of the reciprocal of the pulse width ratio. For example, if the pulse width becomes  $1/4$ , the electric field will be twice as large. Note that this is identical to the case where the threshold decreases by that ratio.

Example: If a laser with a pulse width of 2.5ns and a wavelength of 1064nm is entered into the objective, the upper limit value of the laser energy density must be 0.1 (J/cm<sup>2</sup>).

### 4. Dirt on the lens surface:

If optical elements in the laser path, such as the lens surface, are stained with dust and dirt, the lens and other elements may be damaged by the laser beam. Care should be exercised.

### 5. Precautions on use:

If the reflected beam of the laser emitted from the objective is returned to the optical system, the laser beam will be converged in the system, causing damage to the lens and optical elements (including mirrors and prisms). Do exercise seriously so as not to return the reflected laser beam to the optical system.

Example: To measure the emission energy of the laser-beam machining optical system or to measure the emission factor, a power meter placed behind the laser converging position of the laser beam. In this case the laser beam reflected from the power meter will return and converge into the optical system. This way may cause laser damage to the optical system. Here is an option for kindly reference, which might avoid the damage happened, for example:

- put power meter location at defocused position, 5mm below the beam focused position, as shown in right-side figure.
- make Power meter tilted angle  $15^\circ$  from its orientation perpendicular to the laser beam as shown in right-side figure.

If the power meter is fixed as way showed in the figure at the right, the reflected beam will not return into the optical system directly. This way prevents the system from being damaged by the returned laser beam.

If the power meter is oriented as in the figure at the right, the reflected beam will not return directly into the optical system. This prevents the system from being damaged by the returned laser beam.

Notes: Please be aware above information just for kindly reference, please do contact with the laser provider or supplier for safety consideration before exercising laser application.

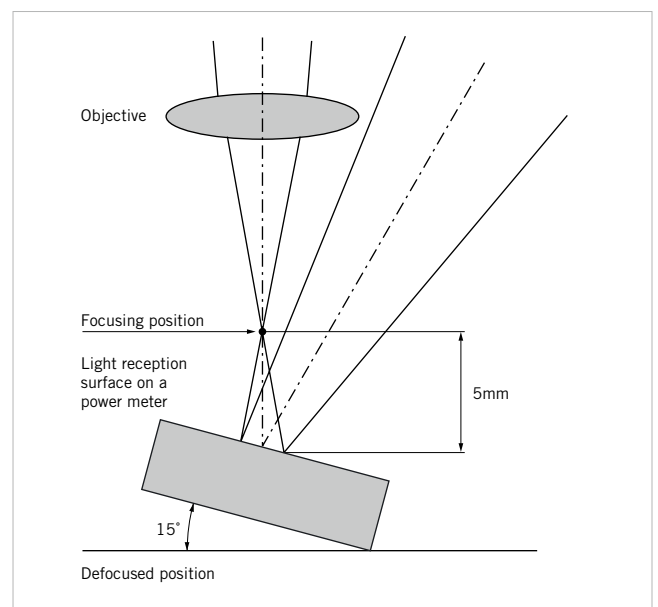



Canada | China | Germany | Spain | USA

# Motic®

[www.motic.com](http://www.motic.com)

**Motic Instruments Inc. (CANADA)**

130 - 4611 Viking Way, Richmond, BC V6V 2K9 Canada  
Tel: 1-877-977 4717 Fax: 1-604-303 9043

**Motic Deutschland GmbH (GERMANY)**

Christian-Kremp-Strasse 11, D-35578 Wetzlar, Germany  
Tel: 49-6441-210 010 Fax: 49-6441-210 0122

**Motic Incorporation Ltd. (HONG KONG)**

Rm 2907-8, Windsor House, 311 Gloucester Road,  
Causeway Bay, Hong Kong  
Tel: 852-2837 0888 Fax: 852-2882 2792

**Motic Spain, S.L. (SPAIN)**

Polígono Industrial Les Corts, Camí del Mig, 112  
08349 Cabrera de Mar, Barcelona, Spain  
Tel: 34-93-756 6286 Fax: 34-93-756 6287

\* **CCIS®** is a trademark of Motic Incorporation Ltd.

**Motic Incorporation Limited Copyright © 2002-2011.  
All Rights Reserved.**

**Design Change :**

The manufacturer reserves the right to make changes in instrument design in accordance with scientific and mechanical progress, without notice and without obligation.



Code: 1300901304741  
Updated: 5.11.2013

